

User Guide

CRI-376

Centrex Recording Interface

DEES

Table of Contents

Introduction 2

The Meridian™ Business Set 3

Key Numbering Plan (18 button add-on) 4

Key Numbering Plan (36 button add-on) 5

Key Numbering Plan (18 & 36 button add-on) 5

Installation 6

Getting Started 8

Programming Applications

Clearing the Memory 9

Recording Lines Selectively

MBS 12

Multi-line Add-on 13

Alert Tone 14

Enabling The Relay 15

Linking Programs 16

Regulatory Notes 17

Warranty and Maintenance information 19

Product Specifications 20

Other DEES Terminal Enhancements 21



Introduction

The Centrex Recording Interface (CRI-376) has been developed to allow users of Meridian Business Sets (MBS) serviced from a Northern Telecom DMS-100™ or SL-100™ to connect their telephones directly to an industrial recording device.

The CRI-376 allows the user to record voice conversations on a *Per Set* basis. *Per Set* is defined as the telephone (MBS) or any associated 18-36 button add-on. Any line or group of lines can be selectively recorded. In addition, a user programmable alert tone may be turned on or off and the relay may be enabled or disabled.

The CRI-376 monitors the telephone line only. No provision is made for transmitting commands to the central office. The CRI-376 must be connected to a Meridian Business Set or the older style Electronic Business Set.

**About the
Meridian
Business Set**

The CRI-376 was built to support the Meridian Business Set manufactured by Northern Telecom. The set may or may not be a display set, the CRI will operate with any 5000 series version.

During the programming process, reference to Keys on the Business Set is made. Key 1 is always the Primary Directory Number. See Fig. 1.

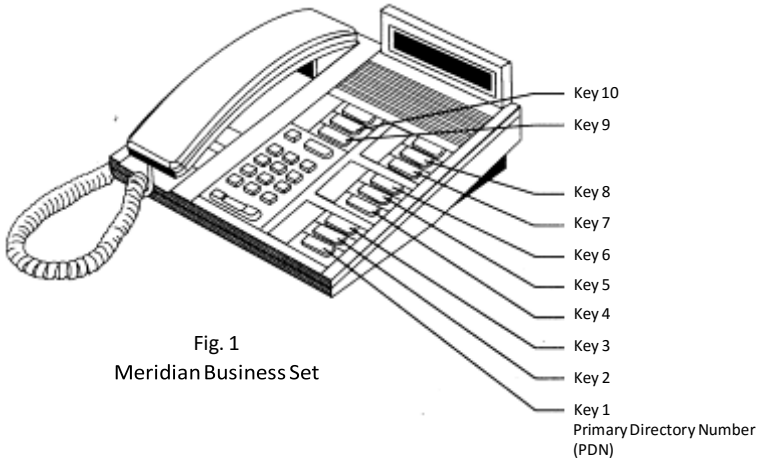
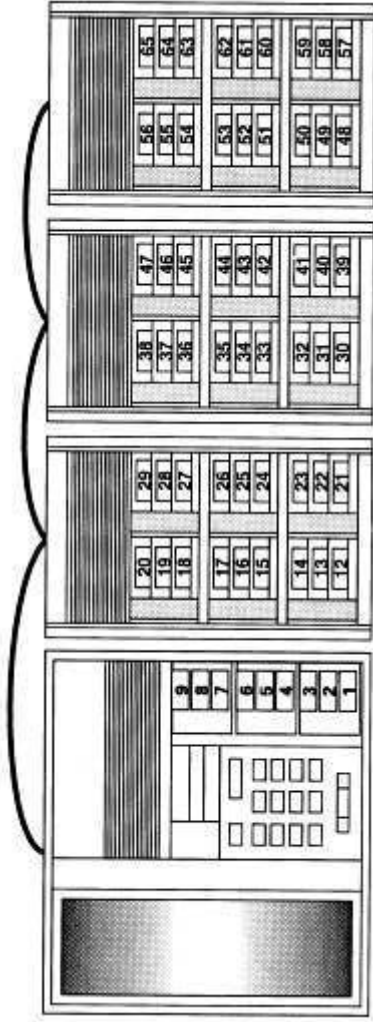

Fig. 1
Meridian Business Set



Key Numbering Plan 18 Button Add-On



**Key Numbering Plan
36 Button Add-On**

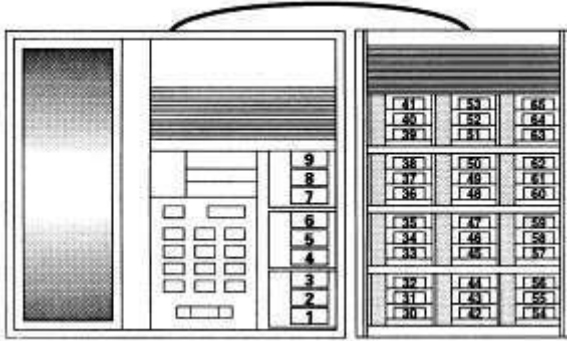

Fig. 3
36 Button Add-On

**Key Numbering Plan
18 Button and 36
Button Add-Ons**

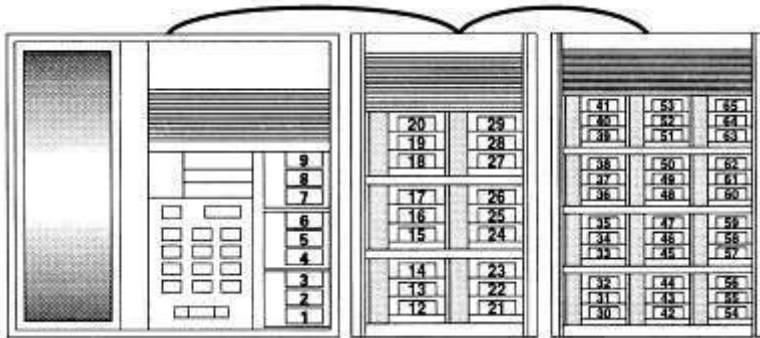

Fig. 4
18 and 36 Button Add-On

Installation of the CRI-376

Depending on the application, the CRI-376 may be installed at the Desk Top or in the Telephone Closet. The following installation instructions will provide the necessary information for Desk Top installation. For the Telephone Closet installation, please refer to Fig. 7 on pages 10 and 11.

Note: The CRI-376 is programmed the same way regardless of the installation method used.

A. Typical Stand-Alone Installation

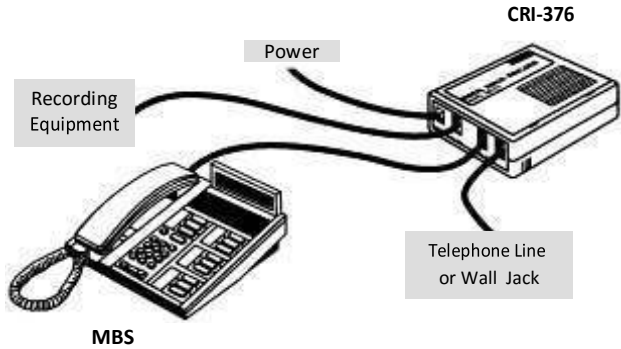

Fig. 5
Desk Top Installation

B. Installation with 'T'-Adapter

If the Business Set that is being used is a model M5112, M5209, M5312 or any set which uses a T-Adapter, simply plug one end of the cord supplied with the CRI into the T-Adapter and the other end into the *Line* jack on the CRI. Plug the MBS into the *Station Set* jack on the CRI. Apply power when ready.

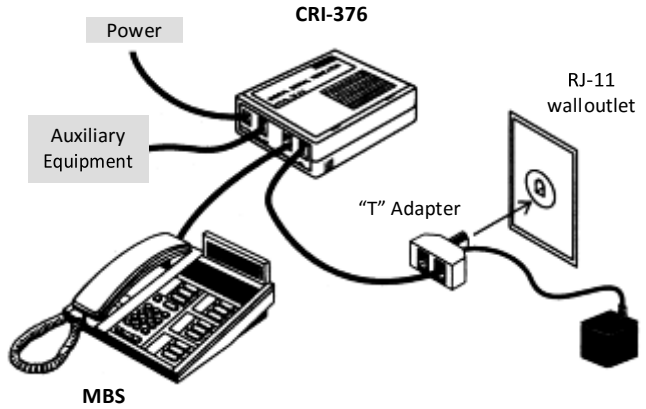

Fig. 6
Installation with "T" Adapter
(MBS models M5112, M5209, M5312)

How to Program the CRI-376

In many cases, the CRI-376's default program "factory settings" will be all that is required.

If this is the case, no further programming is necessary by the user. The *default program* is as follows:

All lines are recorded
(automatic connection to the recording device as soon as the telephone handset is lifted)
Alert Tone is off on all lines
The Relay is disabled

Getting Started

Programming the CRI-376 involves identifying which line or lines are to be recorded and whether or not an alert tone must be heard. Any program input into the CRI is retained in a non-volatile memory until such time as you wish to change it.

If you unplug the CRI, you do not have to reprogram the unit.

The CRI-376 can be programmed to perform the following functions, which are different than the *default program*:

Clear all previous programs
Alert Tone off
Record selected lines on the MBS
Record selected lines on the Add-On
Enable the relay

The programming mode of the CRI-376 is accessed directly after power is applied to the unit. The program is input by pressing keys on the Meridian Business Set touch pad. *All programming is done with the MBS On-Hook.* The CRI-376 must be in programming mode to change the unit's program. You will know that you are in the programming mode because the LED is blinking rapidly.

You have 20 seconds to press the  key before the unit times out and you must start over .

If a mistake is made while programming, i.e. you input an incorrect number disconnect the power from the CRI-376 and start again.

Before any new program is entered into the CRI-376, you should clear the CRI's memory. Clearing the CRI-376's memory will return the unit to the factory default mode. (Refer below).

Before you start to program, we suggest that you write down the configuration string, so that input errors are minimized.

When you have completed programming the CRI, the LED will continue to flash for 20 seconds. It will then time-out and the LED will become steady, after which the unit will be ready to use.

Clearing the Memory

This programming option allows the user to clear the CRI's memory of any currently stored program.

Note: If the CRI has been programmed, i.e. it is no longer in the default mode, this operation must precede any new programming.

Action

Step 1: Apply power to the CRI or disconnect the power and then re-apply. The LED will be flashing rapidly.

Step 2: Press the then press

All previous input programming has been erased and the CRI has been returned to its default program.

Telephone Closet Installation

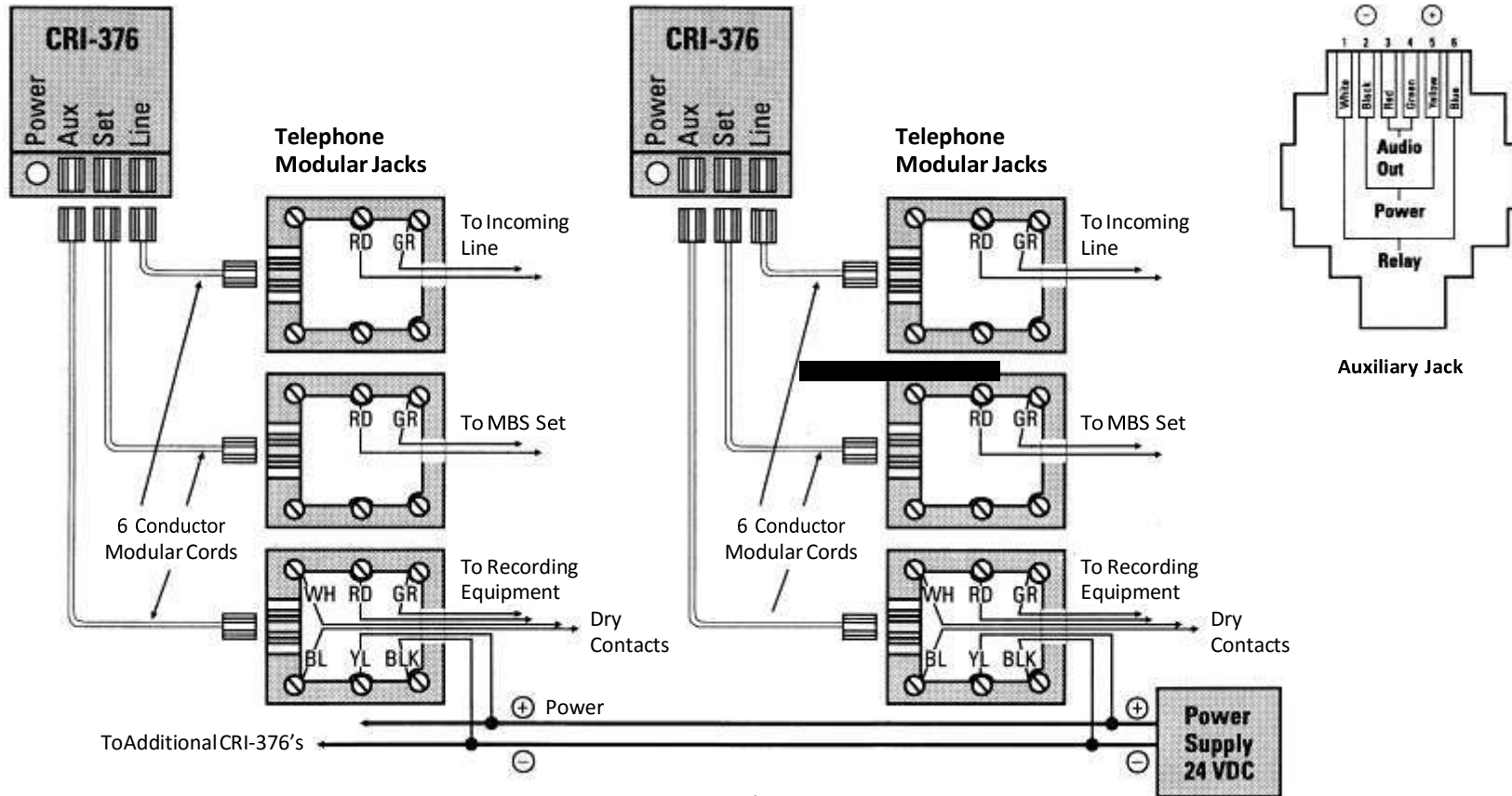

Fig. 7
Multiple CRI-376 Installation (Typical)



Notes:

1. Power Supply = 50 mA per CRI.
2. Do Not use Power Jack when installing this application.
3. For recorders requiring contact closure to operate, connect to white and blue pair of Aux. Jack.

Recording Selective Lines MBS Only

If the user wishes to record individual lines or individual groups of lines, the CRI may be programmed to accomplish this requirement.

Action

- Step 1: Apply power to the CRI or disconnect the power and re-apply. The LED will be flashing rapidly.
- Step 2: Press the  then press 
- Step 3: Select the lines you wish to record by pressing the corresponding Key on the pad.
Refer to Fig. 1 for line key numbering.

The CRI will allow you to record up to 10 lines on the Meridian Business Set.

Pressing the  key on the keypad would select the 10th line on the MBS.

For example, if you wanted to record only lines 1, 2 and 3 the following keys would be pressed after power was applied to the CRI:

Recording Selected Lines Multi-Line Add-On

If the user wishes to record individual lines or individual groups of lines on the MBS Add-On, the CRI may be programmed to accomplish this requirement.

Action

Step 1: Apply power to the CRI or disconnect the power and re-apply. The LED will be flashing rapidly.

Step 2: Press the  then press 

Step 3: Select the number on the key pad of the MBS that corresponds with the key numbering plan illustrated in Fig. 2, Fig. 3 and Fig. 4 on pages 4 and 5.

For example, if you wanted to record only lines 25 and 26, the following keys would be pressed after power was applied to the CRI:

Note:

To program selected lines that appear on both the MBS and the add-on, refer to “Linking Programs Together” on page 16.

Alert Tone

This option will allow the user to turn *on* or *off* the alert tone used to identify to the calling party that the call is being recorded.

Note:

The Alert Tone is either on or off. You cannot individually select which lines can have the Alert Tone, and which cannot.

Action

Step 1: Apply power to the CRI or disconnect the power and re-apply. The LED will be flashing rapidly.

Step 2: Press the then press to turn the Alert Tone *ON*.

The Alert Tone will be activated the next time that a line is recorded from the CRI.

If the Alert Tone has been turned on in a previous application and you now wish to turn it off,

Step 1: Apply power to the CRI or disconnect the power and re-apply. The LED will be flashing rapidly.

Step 2: Press the then press to turn the Alert Tone *OFF*.

Enabling the Relay

If the recording device requires a contact closure to operate it, such as when you lift up the handset, a contact must close to turn on the recorder. The CRI can be programmed to do this.

Note:

The relays are either on or off. No selective programming is possible.

Action

Step 1: Apply power to the CRI or disconnect the power and re-apply. The LED will be flashing rapidly.

Step 2: Press the then press then press to enable the relay.

To **Disable** the relay, repeat Step 1, then

If the Alert Tone has been turned on in a previous application and you now wish to turn it off,

Step 2: Press the then press to disable the relay.

Linking Programs Together

The CRI may be programmed so that several configurations can operate at the same time. For example, you may wish to record lines selectively on both the MBS and its associated add-on. The relays must be on, as must the Alert Tone. The process to do this is called Linking Programs.

No special codes are required to link programs, the user simply creates one complete program string that encompasses all requirements.

Example:

We need to record lines 1, 2, 25 and 26 with the *Alert Tone On*. Our recorder requires a contact closure to operate it.

In this example, the following keys would be pressed:

* 0 * 1 1 * 2 1 2
* 3 2 5 2 6 * 8 1

Regulatory Notes

I. FCC REQUIREMENTS:

1. The federal Communications Commission (FCC) has established Rules, which permit this device to be directly connected to the telephone network. Standardized jacks are used for these connections. This equipment should not be used on party lines or coin lines.
2. If this device is malfunctioning, it may also be causing harm to the telephone network; this device should be disconnected until the source of the problem can be determined and until repair has been made. If this is not done, the telephone company may temporarily disconnect service.
3. The telephone company may make changes in its technical operations and procedures; if such changes affect the compatibility or use of this device, the telephone company is required to give adequate notice of the changes. You will be advised of your right to file a complaint with the FCC.
4. If the telephone company requests information on what equipment is connected to their lines, inform them of:
 - a. The telephone number this unit is connected to
 - c. The USOC jack required
 - d. The FCC registration numberItems 'b' and 'c' are indicated on the label.

Warning:

Changes or modifications to this unit not expressly approved by the party responsible for compliance could void the user's authority to operate the equipment.

NOTE:

This equipment has been tested and found to comply with the limits for a Class A digital device, pursuant to Part 15 of the FCC Rules. These limits are designed to provide reasonable protection against harmful interference when the equipment is operated in a commercial environment. This equipment generates, uses, and can radiate radio frequency energy and, if not installed and used in accordance with the instruction manual, may cause harmful interference in which case the user will be required to correct the interference at his own expense.

II. SERVICE REQUIREMENTS

1. In the event of equipment malfunction, all repairs should be performed by our Company or an authorized agent. It is the responsibility of users requiring service to report the need for service to our Company or to one of our authorized agents. Service can be obtained at:

Dees Communications Corporation
Phone: 1 800 654 5604

FCC Registration No. FCNCAN-65100-PN-N

Canadian Emissions Requirements:

This digital apparatus does not exceed the (Class A) limits for radio noise emissions from digital apparatus set out in the Radio Interference Regulations of the Canadian Department of Communications.



Equipment Attachment Limitations

Notice:

The Canadian Department of Communications label identifies certified equipment. This certification means that the equipment meets certain telecommunications network protective, operational and safety requirements. The Department does not guarantee the equipment will operate to the user's satisfaction.

Before installing this equipment, users should ensure that it is permissible to be connected to the facilities of the local telecommunications company. The equipment must also be installed using an acceptable method of connection. In some cases, the company's inside wiring associated with a single line individual service may be extended by means of a certified connector assembly (telephone extension cord). The customer should be aware that compliance with the above conditions may not prevent degradation of service in some situations.

Repairs to certified equipment should be made by an authorized Canadian maintenance facility designated by the supplier. Any repairs or alterations made by the user to this equipment, or equipment malfunctions, may give the telecommunications company cause to request the user to disconnect the equipment.

Users should ensure for their own protection that the electrical ground connections of the power utility, telephone lines and internal metallic water pipe system, if present, are connected together. This precaution may be particularly important in rural areas.

Caution: Users should not attempt to make such connections themselves, but should contact the appropriate electric inspection authority, or electrician, as appropriate.



Warranty and Maintenance Information

No provisions are made for field adjustment or repair of the CRI-376. If the CRI does not seem to function mechanically, verify connections and check the cable plugs and connectors for proper contact pressure and cleanliness. If the CRI still does not work, replace the unit with a substitute CRI that is known to be functional.

If the problem seems to be software related, for example the configuration that was programmed does not seem to work, reprogram following the individual configuration programming instruction. For further technical assistance, contact Technical Support at:

1 800 654 5604

The CRI is warranted to be free of defects both in material used and in the manufacturing process. This warranty is valid from one year of purchase.

For more complete warranty information, refer to DEES warranty service policy.

Specifications

	Min	Typical	Max	Unit
Electrical				
Supply Voltage	18		28	VDC
Supply Current			50	mA
NOTE: A 24VDC 250 mA wall transformer is an acceptable powersupply.				
Input Impedance				
200 to 4,000 Hz	25			Kohm
DC	2			Mohm
Insertion Loss (200 - 4,000 Hz)		<0.5		dB
Longitude Voltage (60 Hz)		30		VAC
Longitude Balance (200 - 4,000 Hz)	66			dB
Output				
Audio Output Impedance		600		ohm
Gain (300 - 3600 Hz)	-2		+2	dB
Contact Rating				
Relay Contact Rating		10		VA
Switching Power			10	VA
Maximum Switching Voltage		100 VDC or Peak DC		
Switching Current			0.50	A
Carry Current			1.00	A
Alert Tone Output				
Frequency		1400		Hz
Duration		0.5		sec
Repeats		every 15 seconds		
Environmental				
Operating Temp.	32		122	°F
	0		50	°C
Storage Temp.	-40		158	°F
	-40		70	°C
Humidity (non-condensing)			95%	RH
Mechanical				
Dimensions		5" x 5" x 1.5" (L x W x H)		
		12.7 x 12.7 x 3.8 cm		
Shipping Weight		1.40 lbs		
		0.620 kg		



Other Dees Terminal Enhancements

CTA-369

The CTA was the first product in the family of Meridian Digital Centrex enhancements and was built under license to Northern Telecom. The CTA allows standard analog equipment to be connected directly to the MBS line. The CTA enhances the performance of the MBS by eliminating the need for additional analog lines. Some examples of equipment that can be connected to the MBS line using the CTA are:

Answering Machines	Modems
Electronic Mail	Autodialers
Secure Phones	

DSI-375

The DSI-375 is a multi-functional enhancement that can add the following features to your MBS:

- normal ringing for subsequent incoming calls when you are already on a line of the MBS
- additional volume control
- distinctive ringing solutions
- allows the connection of an external loud ringer
- night bells feature

Please call us for more information on our products.



Tel: 800-654-5604 Fax: 888-474-7197 www.dees.com

Meridian is a registered trademark of Northern Telecom.

SL-100 and DMS-100 are trademarks of Northern Telecom.

Printed in Canada 95.119.02G 15.10